



Assembly Instructions

Welded Storage Rack

Model No.: BW2472W4

Dimension: 77" W x 24" D x 72"

Tool Required: Mallet

Congratulations on the purchase of your MuscleRack™.

Edsal Mfg. has taken great pride in manufacturing a high quality product which will ensure many years of pleasurable use.

MuscleRack™ was designed and engineered with the highest standard of quality with the understanding and need for optimal storage flexibility. The shelving is designed for easy assembly; no nut or bolts. Keeping in mind that storage needs change; the rack's beams may be moved up or down to be versatile with your ever-changing storage needs.

Safety Rules and Instructions

Failure to abide by these instruction and safety rules may cause poor product performance and/or failure of the product and validity of product warranty.

1. The storage rack must be assembled and used on a level surface.
2. Evenly distribute the weight of load on each shelf, place the heaviest items on the bottom shelf. **DO NOT OVERLOAD.**
3. **DO NOT STAND ON OR USE THE UNIT AS A LADDER.**
4. Should there ever be a need to change the level of the shelf, be sure to disassemble and reassemble one level at a time.
5. Use a mallet to drive the clip of the beam to the bottom of slots on the end frame. Hit the beam close to the connection.
6. Due to the size of this storage rack, 2 people must assemble.

Customer Service (773) 475-3000

Please call Customer Service for any of the following reasons.

1. Assistance with assembly of your shelf.
2. Replacement parts, Missing Parts or Damaged Parts.

Please having the following information. Model No., Part No. & Description, Purchased Location and Date Purchased.

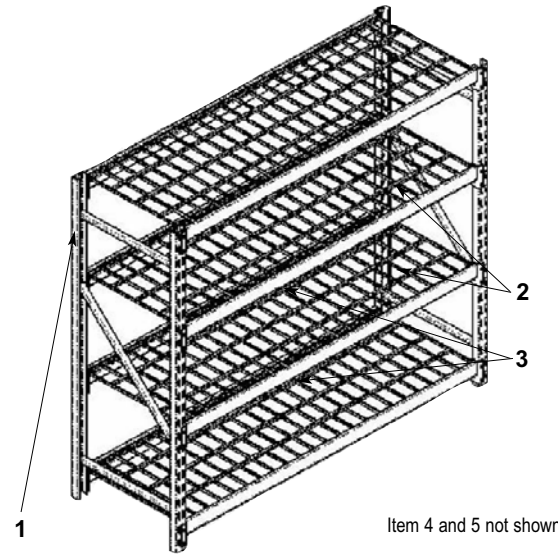

Contents:

Item No.	Description	Qty.
1	Welded End Frame	2
2	Beams	8
3	Wire Deck Shelving	4
4	Front to Back Support	4
5	Plastic safety clips	16

Step 1- Take an End Frames (Item 1) and two Beams (Item 2). Start by assembling the bottom level. Proceed by connecting one end frame at a time.

Refer to detail 1 for connection instruction.

Step 2- Assemble the beam level directly above, and follow by doing the next upper level until complete.

Step 3- Be sure all clips are secured in the slots of the post.

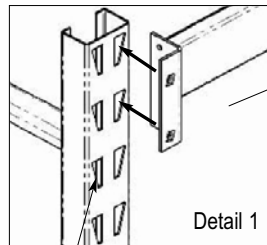

Detail 1

Nota:
If you have more then 2 units you may use the side slots to expand your storage (3 units with 4 end frames)

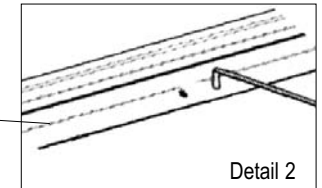
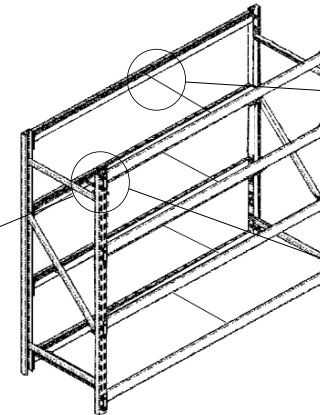

Detail 2

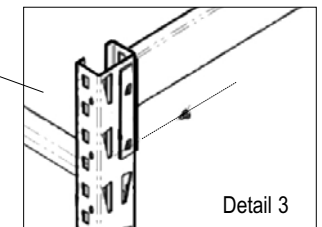

Detail 3

Step 4- Insert the safety clip (item 5) through the beam and frame as shown in detail 3.

Step 5- Insert front to back support (item 4) in the slot of the front and back beam as shown in detail 2

Step 6- Place the wire decking upon the beams, make sure the deck sits in the flange.

Congratulations on completing your storage rack!